

## Gender flip and person marking in Benchnon (North Omotic)

Matthew Baerman  
Surrey Morphology Group, University of Surrey  
m.baerman@surrey.ac.uk

Word count: 8149

**Abstract** Subject agreement in the North Omotic language Benchnon (Rapold 2006) lacks dedicated person marking, but indirectly indicates person distinctions through asymmetries in the distribution of gender markers. In one verbal paradigm, first and second person subjects are expressed by feminine morphology, and in the other paradigm they are expressed by masculine morphology. This is hard to reconcile with any known notion of how gender assignment works. I show that it can be explained as the particular instantiation of a rare but cross-linguistically recurrent pattern in which a (reduced) person marking system is generated by restrictions on gender agreement: only third person subjects control semantic gender agreement, while first and second person are assigned default gender. In Benchnon the default gender switched from feminine to masculine over the course of its history, yielding two contrasting verbal paradigms. The older one is morphologically frozen, the newer one is a reflection of still-active agreement conditions. Further developments show that the older paradigm can be adapted to conform to the newer conditions, showing that the division between morphosyntactically motivated and arbitrarily stipulated morphology is a fluid one.

**Keywords:** inflection, paradigms, gender, person, diachrony

### 1 Introduction

Verbs in the North Omotic language Benchnon, spoken in Ethiopia, make unusual use of gender-marking morphology, in which an alternation between feminine and masculine forms takes the place of person marking. In Rapold's (2006) account, verbal subjects are marked by exponents of gender and number, but not person. The formatives themselves are not unique to verbs, and can also be found in the distal demonstrative, shown in (1). The stem distinguishes feminine singular (*èn-*), masculine singular (*ùç-*) and plural (*ènd-*), while the nominative case marker distinguishes two forms: feminine singular (*-ā*) versus masculine+plural (*-ī*).<sup>1</sup>

- (1) Nominative forms of the distal demonstrative pronoun (Rapold 2006: 389, 480)
- |              |                             |
|--------------|-----------------------------|
| <i>èn-ā</i>  | 'that' (feminine singular)  |
| <i>ùç-ī</i>  | 'that' (masculine singular) |
| <i>ènd-ī</i> | 'those' (plural)            |

These same formatives, with slight modification, are used for subject marking in the verbal system. Final verbs (the main verb of the sentence) have a suffix which is the same as the distal demonstrative stem (usually losing the final /ç/ of the masculine singular), while converbs have a suffixed vowel which is segmentally identical to the nominative case marker.<sup>2</sup> Where the verb

---

<sup>1</sup> The diacritics over the vowels represent tone: from highest to lowest: *ǎ, ă, ǎ̄, ǎ̀, ǎ̂*. There is also a distinct rising tone (from *ǎ̀* to *ǎ̂*), which does not figure in the data discussed here.

<sup>2</sup> Rapold (2006) uses the term *medial verb*; the morphologically and functionally corresponding form in other North Omotic languages has also been variously termed *gerund*, *non-final verb* and *converb*. I have settled here on *converb* as a cover term, since this appears to be the one most used in recent works, e.g. Zaugg-Coretti (2013); Hayward & Chabo (2014); Mamede (2018); Theil (forthcoming).

has a third person subject, the pattern corresponds to the distal demonstrative: feminine singular -*èn/-á* (2), masculine singular -*ù/-í* (3), and plural -*ènd/-í* (4).

- (2) Rapold (2006: 235)  
 sōʔ kīt-á wū ùçk'-èn-ē  
 water draw.water-F.SG she drink-F.SG-MED  
 'She drew water and drank.'
- (3) sōʔ kīt-í yī ùçk'-ù-ē  
 water draw.water-M.SG/PL he drink-M.SG-MED  
 'He drew water and drank.'
- (4) sōʔ kīt-í ìtsàyk'nī ùçk'-ènd-ē  
 water draw.water-M.SG/PL they drink-PL-MED  
 'They drew water and drank.'

With non-third person subjects, these same forms are found, but they are not determined by gender. For example, if the subject is first or second person singular (5), (6), or first person exclusive plural (7), converbs take the feminine singular form, and final verbs take the masculine singular form, regardless of the sex of the subject.

- (5) Rapold (2006: 235)  
 sōʔ kīt-á tā ùçk'-ù-ē  
 water draw.water-F.SG I drink-M.SG-MED  
 'I drew water and drank.' (male or female subject)
- (6) sōʔ kīt-á nē ùçk'-ù-ē  
 water draw.water-F.SG you.SG drink-M.SG-MED  
 'You (SG) drew water and drank.' (male or female subject)
- (7) sōʔ kīt-á nū ùçk'-ù-ē  
 water draw.water-F.SG we.EXCL drink-M.SG-MED  
 'We (EXCL) drew water and drank.' (male or female subjects)

This is strikingly unusual. Not so much because certain person values look as if they have a gender of their own, though that is not exactly common – it is in fact attested in a number of languages from various parts of the world (see §2). Rather, it is the fact that this gender appears to flip between verb paradigms, something which has no parallel in any other language, as far as I know.

The full paradigms are shown in Table 1. Note that converbs make a distinction between 1PL exclusive and inclusive, the former patterning with the 1SG, the latter patterning with the other plural forms. (The 1PL exclusive may alternatively take a dedicated suffix -*o*; see fn 10.) Final verbs have a dedicated plural form for second and third person subjects.

**Table 1:** Benchnon verbal subject agreement paradigms.

Converb 'draw water'				Final verb 'drink'		
	SG	PL			SG	PL
		EXCL	INCL			
1	kìt-á	kìt-í		1	= 3SG M	ùçk'-ènd
2				2		
3 F				3 F	ùçk'-èn	
3 M				3 M	ùçk'-ù	

For third person subjects there is thus a consistent system of gender-number marking that extends beyond the verbal system, and embraces demonstratives and case markers as well. The same morphology is used for first and second person subjects, but without any obvious motivation for the choice of gender marker, and in a way which switches between paradigms. The goal of this paper is to account for this hybrid behavior. The key lies in diachrony. I argue that the use of gender-marking morphology for first and second person subjects is originally due to person-based constraints on gender agreement, which results in their being assigned to the default gender. The two verbal paradigms are the products of two different historical periods, in between which the default gender switched from feminine to masculine. Thus, even though the basic principles of the system remained the same across this span of time, two contrasting patterns were the result.

The paper is structured as follows. §2 provides cross-linguistic support for the idea that person-based asymmetries in gender agreement can bring about the covert marking of person values. §3 shows how this can be applied to the analysis of the Benchnon paradigms, and how these might have evolved. Final verbs are the more recent system, while the converb paradigm is a fossilized relict. §4 shows how the kind of reorganization of gender assignment rules posited for Benchnon may also explain certain covert paradigm splits in Tucanoan language. §5 shows that the converb paradigm might not completely fossilized, and is liable to be reconfigured on analogy with the final verb paradigm. §6 concludes, stressing the dual nature of inflectional paradigms both as the expression of morphological features and as autonomous morphological objects.

## 2 Cross-linguistic parallels

Subject agreement in Benchnon verbs can be understood as an instance where gender marking has the secondary effect of marking person, due to asymmetries in the conditions on agreement. This idea crucially rests on two assumptions, (i) the distinction between semantic gender agreement and syntactic (or *grammatical*) gender agreement (see e.g. Corbett 1991: 225-26), and (ii) the notion of default gender assignment. Semantic gender agreement makes direct reference to the perceived gender of the controller, as with the English pronouns *she*, *he* and *it*. Syntactic gender is derived from properties of the linguistic system (phonological, morphological, or lexical). For example, in Bulgarian, the general rule is that nouns that end in *-a* such as *salata* 'salad' are feminine, and those that end in *-o* such as *meso* 'meat' are neuter; there is no obvious semantic motivation, it is based solely on the form of the noun. The contrast between semantic and syntactic gender assignment can be seen where the controller is human. For example, based its form *bašta* 'father' should be feminine, because it ends in *-a*, and *čičo* 'uncle' neuter, because it ends in *-o*. But here semantic gender takes precedence, and both are masculine.

Default gender constitutes a special case of syntactic gender. This is where gender is assigned by the linguistic system in cases not covered by the normal rules. An obvious instance

would be subject gender agreement in subjectless sentences, where there are no controller semantics, nor any nominal whose phonological, morphological or lexical properties can be referenced. In such cases the system may fall back on one of the available genders (Corbett 1991: 205-12). In Bulgarian, for example, the neuter serves this function, as in the subjectless sentence (8).

(8) *Bulgarian*

Studen-o i e bil-o.  
 cold-N.SG she.DAT.SG AUX.3SG be.PST-N.SG  
 'She was cold.' (literally 'her was cold')

I argue that the pattern of gender marking in the Benchnon verb paradigm reflects two principles of gender assignment. With third person subjects, agreement is semantic, according to sex. But first and second person subjects do not control semantic gender agreement. Instead, they are assigned the default gender. This is a pattern that has been observed in a number of different languages from around the world. The basic principles can be illustrated using Barasana-Eduria, an East Tucanoan language of Colombia. The language has three genders, feminine, masculine and inanimate. Feminine and masculine are reserved for animates – feminine for female people, and masculine more generally for non-sex-specific animates, which includes animals and heavenly bodies; inanimate is used for everything else (Jones & Jones 2019: 425-27). In the pronominal system, these genders are only distinguished in the third person (Table 2). Cross-linguistically, this kind of person-based gender asymmetry in pronouns is common. For example, according to Siewierska (2013), out of 124 languages in her sample where pronouns mark gender, in 106 of them (85%) gender distinctions are found in only part of the system. The split between third person and the rest is particularly common.

**Table 2:** Barasana-Eduria personal pronouns (Jones & Jones 2019: 431).

	singular	plural	
		INCL	EXCL
1	yʉʉ	mani	yʉa
2	mʉʉ	mʉa	
3 INAN	ti		
3 F	soo	ĩina	
3 M	ĩi		

Verbal subject agreement shows the same distribution of gender distinctions as the pronouns (Table 3). Feminine, masculine and inanimate are distinguished only in the third person (as with pronouns, feminine and masculine are conflated in the plural, and the inanimate does not distinguish number). But first and second person subjects, somewhat counterintuitively, take the same form as inanimates. This makes more sense if one thinks of the inanimate as simply being the default gender, assigned in the absence of a recognizable gender controller.

**Table 3:** Barasana-Eduria verb ‘fall’ (Jones & Jones 2019: 493, 496).

present			past		
	singular	plural		singular	plural
1/2	kedia-ha		1/2	kedi-b̥	
3 INAN					
3 F	kedia-b̥	kedia-bã	3 F	kedi-b̥	kedi-bã
3 M	kedia-bĩ		3 M	kedi-bĩ	

Support for this idea comes from the behavior of subjectless sentences, which also take inanimate agreement. Contrast (9a), where the noun ‘sun’ is the subject, and the verb takes masculine singular agreement, with (9b), where there is no overt subject, and the verb takes inanimate agreement. The inanimate thus appears to serve as the default gender. If we assume that first and second person do not control gender agreement, at least for verbal targets, then the pattern in Table 3 emerges as natural.<sup>3</sup> This is also the account that Chacon & Michael (2018) give more generally for the evolution of Eastern Tucanoan agreement paradigms.

(9) *Barasana-Eduria* (Jones & Jones 2019: 433)

- a. B̥to            asi-a-bĩ            b̥ĩhũ.  
 very.much   be.hot-PRS-3SG.M   sun(M)  
 ‘The sun is very hot.’
- b. Asi-a-ha.  
 be.hot-PRS-PRS.3.INAN  
 ‘It is hot.’

Similar examples, in which first and second person subjects are marked by a gender form otherwise reserved for inanimates, can be found in Krongo, a Kadu language of Sudan (Reh 1985), and in various Nakh-Dagestanian languages, where this pattern is restricted to the plural; see Baerman & Corbett (2013) for a survey, and Chumakina, Kibort & Corbett (2007) for a case study of the Dagestanian language Archi.

Of course, this is not the only possible analysis. Since the result is a highly syncretic person-gender-number paradigm, one could simply stipulate the syncretic pattern and regard it as an unanalyzed *morpheme*, or pure morphological object (see Luís & Bermúdez-Otero 2016 for extensive discussion of this notion). But further evidence in favour of treating this in terms of the distribution of gender agreement can be found in the Western Tucanoan languages, whose system is somewhat different from that of Eastern Tucanoan. Consider the suffixed copula forms in Table 4 from Ecuadorian Siona. These are attached to nouns or pronouns. There are two

<sup>3</sup> The qualification *verbal targets* is required in order to accommodate periphrastic constructions, in which the lexical verb appears in a nominalized form that employs nominal gender suffixes. This form is not sensitive to person. For example, in the progressive, the auxiliary ‘do’ follows the usual verbal pattern, whereas the lexical verb agrees in gender with the subject for all persons:

- (i) Jones & Jones (2019: 466)
- |                           |               |     |                          |               |     |
|---------------------------|---------------|-----|--------------------------|---------------|-----|
| a. waa-k̥                 | ja-ha         | j̥  | b. waa-ko                | ja-ha         | j̥  |
| go-M.SG                   | do-PRS.3.INAN | 1SG | go-F.SG                  | do-.PRS3.INAN | 1SG |
| ‘I am going. (masculine)’ |               |     | ‘I am going.’ (feminine) |               |     |

In this respect it resembles the Kulina constructions in (10), where gender agreement on the adjective is likewise not constrained by person.

paradigms, assertive and non-assertive, the latter being used in questions and, with an additional suffix, in reports. The assertive paradigm resembles the verbal paradigms in Barasana-Eduria, except that there is no dedicated 3PL animate form; like first and second person, this too is subsumed under the inanimate. But the non-assertive paradigm is different. The gender-marking forms *-o* (feminine) and *-i* (masculine), instead of being restricted to third person, are used for second person as well. A further variation is seen in the copular paradigm of the northern dialect of Máíhiki, a Western Tucanoan language of Peru (Table 5). The non-assertive paradigm matches that of Siona, with both second and third person subjects taking gender agreement. But the assertive paradigm has pure gender agreement, unconstrained by values of person. Taken together, these facts suggest that gender agreement in such a system can be separated from the values of person that condition it.

**Table 4:** Siona suffixed copula (Wheeler 1987: 171-72; Bruil 2014: 194-95; Chacon & Michael 2018: 66-67).

Assertive			Non-assertive		
	singular	plural		singular	plural
1/2	-a-ʔi		1	-a-je	
3 INAN					
3 F	-a-o		2/3 F	-a-o	
3 M	-a-i		2/3 M	-a-i	

**Table 5:** North Máíhiki suffixed copula (Farmer 2015: 8)

Assertive			Non-assertive		
	singular	plural		singular	plural
INAN	-hã		1	-a-je	
F	-a-o		3 INAN		
M	-a-i		2/3 F	-a-o	
			2/3 M	-a-i	

In all the examples of this type that I am aware of, the gender taken by first and second person controllers is one normally reserved for inanimates. But what happens when a language lacks such a gender? *Kulina*, an Arawan language of Brazil, is an example of this. There are only two genders, feminine and masculine. With human controllers, adjectives take the expected gender agreement, as do third person verbal subjects. But first and second person verbal subjects always take the feminine marker, regardless of sex: contrast the forms of the adjective ‘old’ in (10a) and (10b), where gender marking reflects the sex of the subject, with the corresponding verb forms, which have the feminine form in both cases. (Note that verbs have explicit person marking in addition to gender.)

(10) *Kulina* (Dienst 2014: 81)

- a. hada-i o-ha-ni  
old-M 1SG-COP-F  
‘I am old.’ (male speaker)
- b. hada-ni o-ha-ni  
old-F 1SG-COP-F  
‘I am old.’ (female speaker)

Bond (2019) argues that this comes about because only third person subjects control gender agreement on verbs, and that in other contexts feminine gender is assigned by default.<sup>4</sup> In §3 I argue that this is ultimately how the Benchnon paradigms should also be understood, as the product of default gender assignment in a two-gender system.

### 3 Analysis of the Benchnon paradigms

If we accept the proposition that first and second person subjects in Benchnon are assigned the default gender, that immediately raises a question: what *is* the default gender? Rapold (2006: 169-75) argues, based on a number of criteria, that it is masculine. This is what the final verb paradigm would seem to reflect. But the converb paradigm shows the reverse pattern. The contrast is shown in Table 6, where the two paradigms display a similar shape, but only because the order of feminine and masculine in the table rows are switched.

**Table 6:** Benchnon verbal subject agreement paradigms (repeated from Table 1).

Converb 'draw water'			
	SG	PL	
		EXCL	INCL
1			
2			
3 F	kìt-á		
3 M	kìt-í		

*switched:*

Final verb 'drink'		
	SG	PL
1		
2		
3 M	ùçk'-ù	ùçk'-ènd
3 F	ùçk'-èn	

I argue that this has a historical explanation. Both paradigms arose from constraints on agreement with first and second person subjects, but at different periods. The converb paradigm dates from a time when the default gender was feminine. Subsequent to this the default gender changed from feminine to masculine, but the converb paradigm remained morphologically fossilized. The final verb paradigm developed after, along similar lines to the converb but reflecting the new default gender. Both paradigms have in turn been affected by analogical changes that have altered the distribution of forms used in the plural. The developments are discussed in §3.1 and §3.2, starting with final verbs, as they reflect most clearly the principles of the system. For the sake of consistency I continue to gloss the forms as masculine and feminine, though their actual role within a given paradigm is obviously harder to characterize, and subject to shifting interpretations and diachronic changes.

#### 3.1 Final verbs

Final verbs are a Benchnon innovation among the North Omotic languages, and are transparently derived through suffixation of demonstrative pronouns. Rapold (2007) traces the origin of this strategy to cleft sentences with a headless relative clause; note that the demonstratives *ùç* 'that.M', *èn* 'that.F.', *ènd* 'those' also serve as relative pronouns.<sup>5</sup> This

<sup>4</sup> A similar pattern is found with object marking in Yelmek, a Yelmek-Maklew language of Papua New Guinea (Gray and Gregor 2019). Some verb stems alternate for gender and number on an absolutive basis (the object, or intransitive subject), displaying up to three forms: masculine singular, feminine singular, and plural. 1SG and 2SG always take the feminine form. The authors suggest this should be understood as the *morphological* default form – in effect, an instance of arbitrary morphological syncretism – and not due to feminine being the default gender value. However, they do not provide language-internal evidence in favor of one or the other interpretation.

<sup>5</sup> It is not clear what the gender agreement of headless relative clauses is when the subject of the matrix clause is first person or second person singular. Rapold explicitly states (2006: 584) that “[t]he agreement markers agree in

transparent relationship is an indication that the paradigm is relatively recent, and that the forms were not originally associated with person. And there is evidence that the verbal forms can still be understood as potentially marking gender even with 1SG or 2SG subjects, since the semantic gender can sometimes (though rarely) leak through. For example, both sentences in (11) have a 1SG female subject, but (11a) shows the expected masculine form of the final verb, while (11b) exceptionally shows the semantically justified feminine form. Rapold’s observation is that this is conditioned by discourse, correlated with “focus on the polarity and with thetic statements” (2006: 591).<sup>6</sup>

(11) Rapold (2006: 592, 591)

- a. “... hàç-kán wòg-ńs-á tã yísk-ù-ē” màk-èn.  
 this.M.SG-INESS sit.down-PRF-F.SG 1SG.NOM be.located.PRS-M.SG-MEDDECL say-F.SG  
 ‘“... and I am sitting here” she said.’
- b. wùs-ā “tàn-ā sōʔ-k’án hān-k’-á yísk-èn-ē.”  
 3SG.F-NOM.F.SG 1SG-NOM.F.SG water-INESS go-FS-F.SG be. located.PRS-F.SG-MEDDECL  
 ‘She (said) “I am going to the river.”’

Thus, semantic gender assignment (feminine) can sometimes override syntactic gender assignment (masculine). This is an argument against treating the paradigmatic distribution of the suffix *-u* simply as the product of arbitrary morphological syncretism. Though it functions as a first person marker in (11a), it is still liable to be interpreted as a gender marker, thereby licensing the alternative form in (11b).

The plural suffix *-ènd* remains a problem under this account, because it is found with both third *and* second person subjects, and so does not conform to a third person ~ non-third person split. There are however environments that suggest that *-ènd* was once restricted to third person, and what we see now is a later extension. This occurs in constructions which feature overt pronominal markers suffixed to the verb.

Pronominal suffixes consist of two sets of forms. One is drawn from the independent full form pronouns (Table 7). The other is a set of reduced forms derived from the 3SG pronouns, minus the onglides [w] and [y] (Table 8). In the reduced pronominal suffix paradigm, the feminine singular form is used just for feminine singular, the masculine singular is used for everything else.

**Table 7:** Full pronouns (Rapold 2006: 342).

	singular	plural		honorific
		EXCL	INCL	
1	tàn	nòn, nùn	nìn	-----
2	nèn	yìnt-àyk’ñ		yìnt
3 F	wùs	ìts-àyk’ñ		íts
3 M	yìs			

gender/number with the noun phrase that would code the referent of the relative clause, if it were present” but the only relevant example involves a first person singular male subject, which is not diagnostic.

<sup>6</sup> Rapold does not specify exactly how these conditions are manifested in the given example.



**Table 8:** Reduced pronominal suffixes (Rapold 2006: 367).

	SG	PL
1		
2		
3 M	-ɨs	
3 F	-ùs	

The pronominal suffixes are used in two constructions. In the first one, a full form first or second person pronoun is suffixed to the verb, preceding the usual subject marker. This construction signals focus on the verb or its polarity (Rapold 2006: 363).

- (12) Rapold (2006: 222)  
 hám-n̄s-ár-tàn-ù.  
 go.NFS-FUT-NEG-1SG-M.SG  
 'I will *not* go!'

In the other construction, a reduced 3SG pronoun is found *after* the final verb subject marker. This occurs in the counter-expectational mood.<sup>7</sup>

- (13) Rapold (2006: 369)  
 tà                      àt-ù-ɨs-è<sup>8</sup>  
 1SG.NOM              reach-M.SG-M.SG-MED<sub>COUNT</sub>EX  
 'I arrived!'

Table 9 shows how the pronominal markers combine with the subject markers of the final verb. Crucially, the plural marker *-ènd* is not found with 2PL subjects, in contrast to the normal final verb paradigm. Rapold (2006: 366) reports that he was not able to obtain a 3PL subject form for the first construction, but in any case the absence of *-ènd* with a 2PL subject can be confirmed.<sup>9</sup>

**Table 9:** Combination of pronominal suffixes + final verb subject markers.

Full pronominals				Reduced pronominals			Cf. no pronominals		
	SG	PL			SG	PL		SG	PL
		EXCL	INCL						
1	-tàn-ù	-nõn-ù	-n̄n̄n-ù	1			1		
2	-nèn-ù	-ìnt-ù		2			2		
3 M	-ù	(-ènd ?)		3 M	-ù-ɨs	-ènd-ɨs	3 M	-ù	-ènd
3 F	-èn			3 F	-èn-ùs		3 F	-èn	

The shape of the 2PL form in the verbal construction that employs the full form pronominal suffixes gives a possible indication of the relative age of the two alternative distributions of *-ènd*. The form *-ìnt* does not actually correspond to the 2PL pronoun, but rather to the second person honorific, as shown in Table 7. This was however the original form of the

<sup>7</sup> It also occurs in certain relative clause types, but in this case not alongside the final verb subject marker.

<sup>8</sup> *Tā* is a reduced alternative to the full form 1SG pronoun *tàn-ā*.

<sup>9</sup> Rapold (2006: 342) suggests the form *-īts*, corresponding to what is now the third person honorific pronoun, presumably on analogy with the 2PL. That would imply the suffix sequence *\*-īts-ènd* for the 3PL. Alternatively, one might suppose that the absence of overt pronominal suffixation seen in the 3SG carried over to the 3PL as well, yielding simply *\*-ènd*.

2PL pronoun. Following a cross-linguistically familiar path, the honorific use of a plural pronoun ultimately took over its original function, and a new plural form was subsequently derived to express the number contrast in non-honorific contexts, through suffixation of *-äyk'ñ* (Rapold 2006: 343). The paradigm with the pronominal suffix thus preserves the older meaning of the 2PL form, suggesting it might also preserve the older configuration of the other parts of the paradigm. On that interpretation, the original split in the paradigm was between third person and the rest, and the extension of *-ènd* to 2PL subjects was a later development. What motivated this extension is unclear, though the analogical influence of the converb paradigm is a possibility (see discussion of Table 15 in §3.2).

### 3.2 Converbs

Converbs do not have the properties described in §3.1 for final verbs. First and second person singular do not take the default gender. There is no semantic leakage in agreement, as may happen with final verbs: a 1SG or 2SG male subject always takes the feminine form. There is no variation in the paradigmatic distribution of the forms, as seen with final verbs when they take pronominal suffixes. There is thus no *prima facie* reason to treat the converb forms as anything other than a highly syncretic person-gender-number paradigm. But the overall shape of the paradigm is suspiciously similar to that of the final verbs. I suggest here that converb paradigms originated in the same way, as a restriction on gender agreement with non-third person controllers. Subsequent changes both to the gender assignment rules and to the paradigm itself have obscured this, so in effect we have the fossilized and distorted relict of a prior state of affairs.

The converb paradigm, with variants, is shared across the North Omotic languages, indicating that it is of some antiquity – certainly older than the final verb paradigm. In many of these languages it functions as a converb, as in Benchnon, though it may also serve, with further elaborations, as the basis for finite verb paradigms. Hayward (1998) traces its origin to encliticization and subsequent suffixation of the topic pronouns *\*i* ‘he’ and *\*a* ‘she’. This is also the origin of the nominative case markers found in Benchnon and other North Omotic languages. Hayward describes four different paradigm configurations, which for convenience I label types A-D (Table 10). Type A is represented by Benchnon. Type B is exemplified in Table 11 by Gamo,<sup>10</sup> Baskeet and Wolaytta, all languages of the Ometo branch.<sup>11</sup> Type C is exemplified in Table 12 by Kafa. Type D is exemplified in Table 13 by Shinassha and Yemsa.<sup>12</sup>

---

<sup>10</sup> Gamo paradigms also show the possible origin of the 1PL exclusive suffix that may alternatively appear in Benchnon (Hayward 1998: 99, fn 13). In that language, further verbal paradigms have been derived through suffixation of TAM and pronominal markers to the converb. The pronominal element in these cases is *-o*, e.g. 1PL affirmative perfect *geli-d-ǝ-s* ‘enter’ (Hayward 1998: 95). Somehow this element has made its way into the converb form in Benchnon.

<sup>11</sup> Hayward (1991: 536, fn 3) reports that the North Ometo variety Zala additionally uses *-i* for 3SG F too. However, the source for that (Cerulli 1929: 39) does not have a complete paradigm, but simply notes in the text that 3SG gerund suffix is *-ida*, and the only relevant example has a masculine subject.

<sup>12</sup> In the Yemsa paradigms given by Zaugg-Coretti (2013: 216), the feminine/masculine gender distinction in 3SG is maintained in the plural, making it a variant of type D. In her description, third person pronouns also show a gender distinction in the plural, lacking in Lamberti’s description. I do not know where this difference comes from (recent language change? dialect differences?), but it may be worth noting that no other North Omotic language I am aware of has a gender distinction in the 3PL, so the variety described by Zaugg-Coretti is an outlier.

**Table 10:** Converb (or gerund) paradigm schemas in North Omotic.

Type A (Benchnon)				Type B			Type C			Type D		
	SG	PL			SG	PL		SG	PL		SG	PL
		EXCL	INCL									
1				1			1			1		
2				2			2			2		
3 F	-a			3 F	-a		3 F	-a		3 F	-a	
3 M	-i			3 M	-i		3 M	-i		3 M	-i	

**Table 11:** Examples of type B (Hayward 1998: 97; Treis 2014: 47; Wakasa 2008: 803).

Gamo simple converb ('enter')			Baskeet affirmative perfective ('tell')			Wolaytta short converb		
	SG	PL		SG	PL		SG	PL
1			1			1		
2			2			2		
3 F	gel-a		3 F	sool-a-de		3 F	-a	
3 M	gel-i		3 M	sool-i-de		3 M	-i	

**Table 12:** Example of type C (Theil forthcoming).

Kafa imperfective converb ('go')		
	SG	PL
1		
2		
3 F	hamm-aa	
3 M	hamm-ii	

**Table 13:** Examples of type D (Lamberti 1993a: 158; Lamberti 1993b: 196).

Shinassa perfective gerund ('go')			Yemsa preterite gerund ('speak')		
	SG	PL		SG	PL
1			1		
2			2		
3 F	àmm-àá-tè		3 F	woller-á	
3 M	àmm-è-té		3 M	woller-é	

Hayward's reconstruction of the historical evolution of these paradigms is summarized in Table 14. He suggests that the Benchnon paradigm, with its inclusive-exclusive distinction, is the most conservative, and that the other types are derived through (i) generalization of the inclusive form (type B), or (ii) generalization of the exclusive form (type C), with (iii) further restrictions on the domain of *-i* (type D).

**Table 14:** Evolution of North Omotic converb paradigms per Hayward (1998).

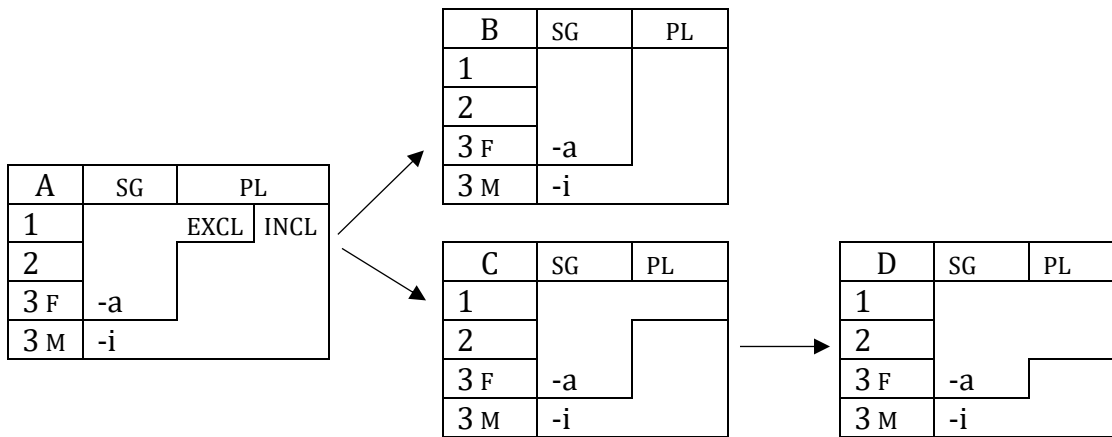

I suggest instead that type D was the point of departure of the evolution, as outlined in Table 15. There are two arguments in favor. The first is typological (see §2): this looks exactly like the sort of system of person-conditioned gender agreement seen in other languages, with a split between third person and the rest. The further evolution of the paradigm can then be understood as the generalization of a consistent strategy for marking plurals, by extending the 3PL form to first and second person as well. I see no clear basis for reconstructing a particular order to these extensions: in Benchnon 1PL is included or not depending on whether it is inclusive or exclusive, while the other types, which do not distinguish clusivity, follow one or the other pattern.<sup>13</sup> The extension of 3PL morphology to other persons thus matches what has been posited for the suffix *-ènd* in the final verb paradigm (§3.1).

**Table 15:** Revised model of the evolution of North Omotic converb paradigms.

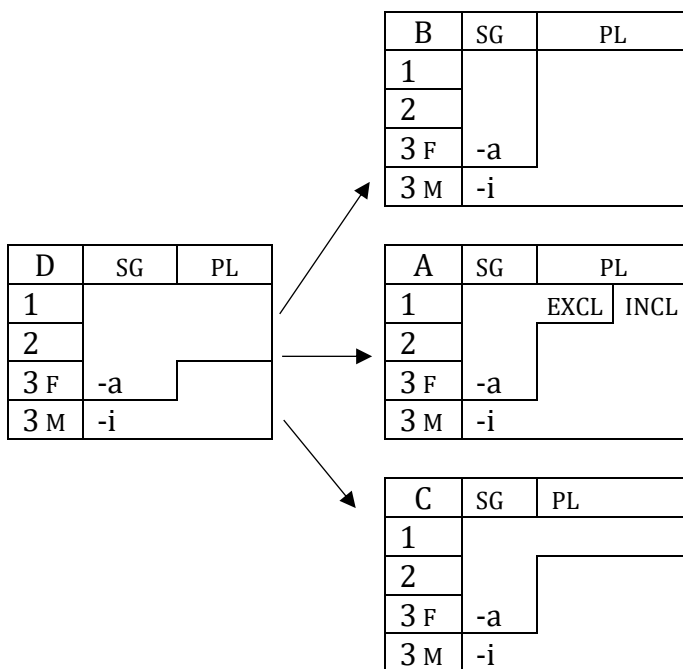

<sup>13</sup> One attractive alternative would be to consider type A as an intermediate step, with types C and B as alternative outcomes of the elimination of the clusivity distinction. There is however no actual evidence to support this.

The second argument in favor of this account is genetic. As shown in the family tree in (14), types A-C are restricted to individual languages or branches within North Omotic, whereas type D is found in two separate branches (Gimojan and Kafa).<sup>14</sup> On Hayward's account, type D would have had to have been innovated on two separate occasions. (For that matter, type C would also have had to have been innovated twice, as it is the precursor stage.) On the present account, type D is an archaism, so its genetic distribution does not require an explicit justification.

(14) Distribution of converb paradigm types across North Omotic (Fleming 1976; Amha 2012)

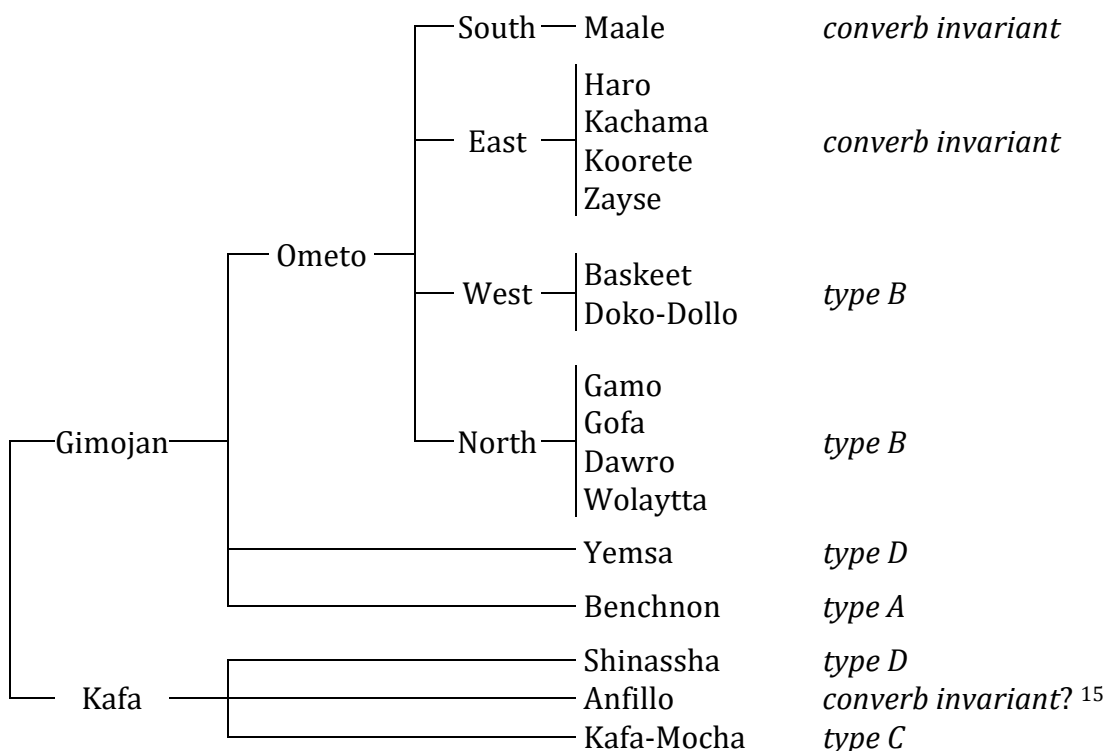

One further argument in favor of the proposed sequence is that type D is a plausible precursor to the uninflected type found in South and East Ometo and, possibly, in Anfillo. The data on Shinassha (type D) suggest that there has been an ongoing loss of subject agreement since the 1950s. Shinassha has two converbs, one for the past and one for the present-future. In Plazikowsky Brauner's (1950) description, both inflect for subject on the type D pattern. In addition, the past converb falls into two inflection classes, with two distinct sets of vocalic suffixes: compare 'go' and 'work' in Table 16. More recent accounts show a reduction of both the number of paradigmatic distinctions and of the inflection class distinctions. Table 17 shows how the descriptions have changed over time. In Lamberti's (1993a: 159-61) account, the inflection class distinction in the past converb (or *perfective gerund* in his terms) has been eliminated, and the present-future has a single invariant form, while in Joswig's (2008: 37) and Mamede's (2018: 252-53) even more recent descriptions, both converbs are simply invariant.

<sup>14</sup> As an anonymous referee points out, Kafa-Gimojan in fact form just one branch of North Omotic in Fleming's (1976) classification, but most of his remaining branches are no longer generally considered to be related to it (see e.g. Güldemann 2018: 330-40).

<sup>15</sup> Yigezu & Yehualashet (1995) report that Anfillo lacks both subject agreement on verbs and gender agreement in general, though they do not supply information specifically about the converb. Limited subject person-number agreement is in fact found with one auxiliary verb (Yigezu & Yehualashet 1995: 109).

**Table 16:** Shinassha converbs according to Plazikowsky Brauner (1950: 74-75).

past converb, class I (‘go’)		
	SG	PL
1		
2		
3 F	amát(i)	
3 M	amét(i)	

past converb, class II (‘work’)		
	SG	PL
1		
2		
3 F	finét	
3 M	finít	

present-future converb (‘go’)		
	SG	PL
1		
2		
3 F	amér	
3 M	amír	

**Table 17:** Stages in the evolution of the suffix vowel of the Shinassha converb

Plazikowsky Brauner (1950)			
	PST		PRS-FUT
	class I	class II	class I/II
elsewhere	-a-	-e-	-e-
3 M/3PL	-e-	-i-	-i-

>

Lamberti (1993a)	
PST	PRS-FUT
-a-	-ə-
-ə-	

>

Mamede (2018)	
PST	PRS-FUT
-a-	-i-

The unresolved point in this account, of course, is that all the evidence we have from Benchnon points to the masculine as the default gender. This diachronic scenario proposed for the converb assumes feminine default gender, which means that the default gender must have changed at some point. In fact, Hayward (1989) has already proposed such a switch to account for the position of Zayse within the East Omoto languages. The default gender in this branch is generally masculine: feminine is reserved for female animates, and masculine is used for everything else, e.g. inanimate nouns, and the subjects of impersonal verbs are masculine in these languages. In Zayse it is the reverse. And while the converb in East Omoto languages itself does not show agreement, there is a morphological trace of this switch in the form of the suffixed copula. In Zayse it is *-tte*, reconstructable as an earlier feminine marker, while the other languages have *-kko*, reconstructable as an earlier masculine marker. Hayward suggests it was Zayse that underwent a diachronic switch from default masculine to default feminine, in as much as it is the outlier. While in general it does seem that masculine is the default in North Omotic, e.g. in Baskeet (Yvonne Treis, p.c.), Shinassha (Lamberti 1993a: 61), Gamo (Hayward and Chabo 2014: 73-74), there are languages that have been reported to have feminine as the default gender, namely Maale (Amha 2001: 45-46) and Yemsa (Lamberti 1993b: 69; Zaugg-Coretti 2013: 136). Therefore no matter what gender one posits as the default for the ancestral system, that will have switched in different daughter branches. In that case it is not implausible to reconstruct feminine as the default gender of North Omotic at the time of the genesis of the converb paradigm, with a subsequent switch.

#### 4 Paradigm splits in Western Tucanoan

The sort of shift in gender-assignment rules posited in §3.2 may also account for paradigm splits found in Western Tucanoan languages, suggesting that it may not be an isolated phenomenon. Consider the contrast in Table 18 between the Siona suffixed copula and a verbal paradigm.<sup>16</sup>

<sup>16</sup> Verbs fall into two inflection classes (i-verbs and non-i-verbs), but the shape of the paradigm is the same in both.

**Table 18:** Siona copular and verbal paradigms, assertive forms (Bruil 2014: 185, 187, 193-94).

	copula	verb 'take'	
		present	past
3PL AN	-a-ʔi	saa-ji	saa-wi
1/2			
3 INAN	-a-bi	saa-hi	saa-bi
3SG M			
3SG F	-a-o	saa-ko	saa-o

Recall that in §2 it was claimed that the inanimate serves as the default gender, and is assigned to those values of person which do not control semantic gender agreement (first and second person, or just first person in the non-assertive paradigm; also all plurals). But that is true only for the copula.<sup>17</sup> With verbs, inanimates take the same agreement as 3SG masculines (Wheeler 1987: 151; Chacon & Michael 2018: 66). This split divides West Tucanoan verbs on one hand from the West Tucanoan copula and the East Tucanoan verb on the other, as summarized in Table 19.

**Table 19:** Comparison of Eastern and Western Tucanoan agreement suffixes (assertive forms).

	Eastern Tucanoan (Barasana-Eduria verb)	Western Tucanoan (Siona)	
		copula	verb
3PL AN	-bã	-ʔi	-ji/-wi
1/2	-ha/-bɥ		
3 INAN			-hi/-bi
3SG M	-bĩ	-bi	
3SG F	-bõ	-o	-ko/-o

According to Chacon & Michael's (2018) reconstruction, subject agreement in Tucanoan arose through the grammaticalization of masculine and feminine suffixes for the third person singular, leaving everything else to be covered by an 'elsewhere' form. Eastern Tucanoan languages then created an additional 3PL form for animates (Chacon & Michael 2018: 61). They do not explicitly discuss how to interpret the variant treatment of third person inanimates, but against this background, the shape of the Western Tucanoan verbal paradigm must be an innovation. The proposed evolution is sketched in (15).

(15) Proposed evolution of Tucanoan paradigm configurations.

B		A		C
3PL AN		3PL AN		3PL AN
1/2		1/2		1/2
3 INAN	←	3 INAN	→	3 INAN
3SG M		3SG M		3SG M
3SG F		3SG F		3SG F

The starting point will have been like the Western Tucanoan copula, with a three-way distinction between 3SG masculine, 3SG feminine, and everything else (type A). Eastern Tucanoan languages

<sup>17</sup> Evidence from Koreguaje, a Western Tucanoan language of Colombia, suggests that the copular pattern of agreement may be induced by other verbal suffixes as well. Cook & Gralow (2001: 16) report that when a verb has a suffixed negator, inanimate subjects take the 'elsewhere' form, rather than the 3SG M.

innovated a distinct 3PL animate form (type B). Western Tucanoan languages reassigned inanimate controllers to the masculine singular in the verbal paradigm (type C). This last change is clearly connected to a shift in default gender assignment, at least in Siona, in as much as subjectless constructions are also affected. Thus the Siona form in (16) has verb in the 3SG masculine form, while its correspondent in the East Tucanoan language Barasana-Eduria has the verb in the inanimate ‘elsewhere’ form (17), the one also used for first and second person subjects.

(16) *Siona* (Wheeler 1987: 219)  
 hasu-hi  
 be.hot-PRS.3SG.M  
 ‘it is hot’

(17) *Barasana-Eduria* (repeated from 9b)  
 Asi-a-ha.  
 be.hot-PRS-PRS.3.INAN  
 ‘It is hot.’

As a consequence of this shift, what used to be underspecified default agreement forms have become dedicated non-third person singular forms. In this respect Western Tucanoan verbs are like North Omotic converbs: the original motivation for the distribution of forms is gone, leaving a morphologically stipulated syncretic paradigm in its wake.

## 5 Realignment of converb inflection

In the scenario advanced in §3.2, converbs are a fossilized relict of the time when feminine was the default gender, and now have what is simply a morphologically stipulated syncretic paradigm. But there are some indications that converb inflection in Benchnon can still be reinterpreted in accordance with the current masculine default. This happens in the prohibitive (i.e. negative imperative), a periphrastic construction which combines a converb (the lexical verb) and the imperative of the verb ‘stay’, which functions as the negative auxiliary. The converb reflects second person agreement, as expected given the referent, while the auxiliary has forms which are specific to the imperative: no suffix in the singular and *-nd* in the plural.

(18) Rapold (2006: 244)

a. mʔ-ā	ʃid	b. mʔ-ī	ʃid-nd
eat-F.SG	stay	eat-M.SG	stay-PL
‘don’t eat’ (SG)		‘don’t eat’ (PL)	

But Rapold reports that some younger speakers show the reverse pattern on the converb, with masculine marking in the singular and feminine marking in the plural:

(19) Rapold (2006: 245)

a. mʔ-ī	ʃid	b. mʔ-ā	ʃid-nd
eat-M.SG	stay	eat-F.SG	stay-PL
‘don’t eat’ (SG)		‘don’t eat’ (PL)	

One possible explanation for this innovation is that the converb has copied the paradigmatic structure of the final verb. In the singular this is transparent, because the masculine form is used, matching what a 2SG final verb would do. In the plural the correspondence is less



straightforward, since, unlike the final verb, the converb has no dedicated plural form. What might have happened is that speakers took the one available form, the feminine, effecting a kind of polarity shift (Hetzron 1967; Baerman 2007). That is, given the formal opposition of *-i* ~ *-a* and the functional opposition of SG ~ PL, if the association of *-i* is switched from PL to SG, then the reassociation of *-a* follows by analogy. It remains unclear why this only happened in the prohibitive, though the fact that this paradigm has limited scope (second person subjects only) may play a role.

## 6 Conclusion

This paper has set out to explain why first person and second person singular subjects in Benchnon are expressed by feminine forms in one paradigm, and by masculine forms in another. The explanation offered here has two parts. First, the use of gender marking morphology to indicate first and second person is due to default gender assignment. In this language, semantic gender agreement according to the sex of the controller is restricted to third person subjects; first and second person controllers are assigned the default gender value. Support for this claim comes from the fact that similar patterns are attested in a small but diverse set of languages from around the world, suggesting there is a systematic principle underlying it. The second part of the explanation is the idea that the default gender switched at some point in history. This occurred after the formation of one of the paradigms (the converb), but before the formation of the other (the final verb). Since default gender appears to vary among the North Omotic languages, this is not an implausible suggestion. (Likewise, Tucanoan languages also show evidence of a historical shift in default gender assignment.)

As a result, the two Benchnon paradigms represent two variations on a theme, one reflecting a still-operating set of agreement conditions, the other a morphologically frozen echo of a similar set of conditions. But the story does not end there, because the way the prohibitive paradigm has developed indicates that the seemingly arbitrary syncretism of 2SG with 3SG feminine agreement may be reinterpreted as bona fide gender marking, and realigned to match the gender-marking pattern of the final verb. This shows a possible third stage in the historical process, where a ‘frozen’ pattern is thawed, as it were, and redeployed under a newer set of conditions. Such a development shows that the division between morphosyntactically motivated morphology and arbitrarily stipulated morphology is a fluid one.

## Abbreviations

1/2/3 = first/second/third person, AN = animate, AUX = auxiliary, COP = copula, EXCL = exclusive, DAT = dative, F = feminine, FS = factual stem, FUT = future, GEN = genitive, INAN = inanimate, INCL = inclusive, INESS = inessive, M = masculine, MED = mediative, MED<sub>COUNTEX</sub> = mediative counter-expectational, MED<sub>DECL</sub> = mediative declarative, N = neuter, NEG = negative, NFS = non-factual stem, NOM = nominative, OBJ = object, PL = plural, PRF = perfect, PRS = present, PST = past, SG = singular

## Acknowledgements

I would like to thank Greville Corbett and Borja Herce for their observations on earlier drafts of this paper, and Rolf Theil and Yvonne Treis for helpful discussions of the Omotic data. Enrique Palancar provided insightful comments on the material in §4. I’d also like to thank three anonymous reviewers, whose efforts led to substantial improvements in the text.

## Funding

This work was funded by the Arts and Humanities Research Council (UK), under grants AH/N00163X/1 ('Loss of Inflection') and AH/N006887/1 ('Lexical Splits'). Their support is gratefully acknowledged.

## References

- Amha, Azeb. 2001. *The Maale language*. Leiden: Research School of Asian, African and Amerindian Studies, Leiden University.
- Amha, Azeb. 2012. Omotic. In Zygmunt Frajzyngier & Erin Shay (eds), *The Afroasiatic languages*, 423–504. Cambridge: Cambridge University Press.
- Baerman, Matthew & Greville G. Corbett. 2013. Person by other means. In Dik Bakker & Martin Haspelmath (eds), *Languages across boundaries: Studies in memory of Anna Siewierska*, 13–26. Berlin: Mouton de Gruyter. doi.org/10.1515/9783110331127.
- Baerman, Matthew. 2007. Morphological reversals. *Journal of Linguistics* 43(1). 33–51. doi.org/10.1017/S0022226706004440.
- Bond, Oliver. 2019. Where are gender values and how do I get to them? In Matthew Baerman, Oliver Bond & Andrew Hippisley (eds), *Morphological perspectives*, 327–369. Edinburgh University Press. www.jstor.org/stable/10.3366/j.ctvvgx4p0.
- Bruil, Martine. 2014. *Clause-typing and evidentiality in Ecuadorian Siona*. Leiden: Leiden University dissertation. hdl.handle.net/1887/23938.
- Cerulli, Enrico. 1929. Note su alcune popolazioni sidama dell'Abissinia meridionale, 2: Sidama dell'Omo. *Rivista degli studi orientali* XII. 1–69. www.jstor.org/stable/41923273.
- Chacon, Thiago Costa, & Lev Michael. 2018. The evolution of subject-verb agreement in Eastern Tukanoan. *Journal of Historical Linguistics* 8(1). 59–94. doi.org/10.1075/jhl.16024.cha.
- Chumakina, Marina, Anna Kibort & Greville G. Corbett. 2007. Determining a language's feature inventory: Person in Archi. In Peter K. Austin & Andrew Simpson (eds) *Endangered languages (Linguistische Berichte 14)*, 143–172. Hamburg: Helmut Buske.
- Cook, Dorothy M. & Frances L. Gralow. 2001. *Diccionario bilingue Koreguaje-Espanol, Espanol-Koreguaje*. Bogotá: Ed. Alberto Lleras Camargo. www.sil.org/resources/archives/19014.
- Corbett, Greville G. 1991. *Gender*. Cambridge: Cambridge University Press. doi.org/10.1017/CBO9781139166119.
- Dienst, Stefan. 2014. *A grammar of Kulina*. Berlin: De Gruyter Mouton. doi.org/10.1515/9783110341911.
- Farmer, Stephanie Jo. 2015. *Establishing reference in Máihìkì*. Berkeley, CA: University of California dissertation.
- Fleming, Harold C. 1976. Omotic overview. In M. Lionel Bender (ed.), *The Non-Semitic languages of Ethiopia*, 298–323. East Lansing, Michigan: African Studies Center, Michigan State University.
- Gray, James & Tina Gregor. 2019. Gender/number syncretism in Yelmek verbal suppletion. Ms., Australian National University. ling.auf.net/lingbuzz/004776.
- Güldemann, Tom. 2018. Historical linguistics and genealogical language classification in Africa. In Tom Güldemann (ed.), *The languages and linguistics of Africa*, 58–444. Berlin: DeGruyter Mouton. doi.org/10.1515/9783110421668-002.
- Hayward, Richard J. 1989. The notion of 'default gender': A key to interpreting the evolution of certain verb paradigms in East Omoto, and its implications for Omotic. *Afrika und Übersee* 72. 17–30.

- Hayward Richard J. 1991. Concerning a vocalic alternation in North Omotic verb paradigms. *Bulletin of the School of Oriental and African Studies* 54(3). 535–553. [www.jstor.org/stable/619061](http://www.jstor.org/stable/619061).
- Hayward, Richard J. 1998. The origins of the North Omoto verb agreement systems. *Journal of African Languages and Linguistics*. 19(2). 93–112. doi.org/10.1515/jall.1998.19.2.93.
- Hayward, Richard J. & Eshetu Chabo. 2014. *Gamo-English-Amharic dictionary with an introductory grammar of Gamo*. Wiesbaden: Harrassowitz.
- Hetzron, R. 1967. Agaw numerals and incongruence in Semitic. *Journal of Semitic Studies* 12. 169–193. doi.org/10.1093/jss/12.2.169.
- Jones, Wendell H. & Paula S. Jones. 2019. *Bilingual dictionary: Eduria & Jānerā – English, English – Eduria & Jānerā*. SIL International. [www.colombia.sil.org/es/resources/search/language/bsn](http://www.colombia.sil.org/es/resources/search/language/bsn).
- Joswig, Andreas. 2008. *A brief grammar of the Borna language*. Addis Ababa: SIL Ethiopia. [www.sil.org/resources/publications/entry/68934](http://www.sil.org/resources/publications/entry/68934).
- Lamberti, Marcello. 1993a. *Die Shinassha-Sprache*. Heidelberg: Carl Winter.
- Lamberti, Marcello. 1993b. *Materialien zum Yemsa*. Heidelberg: Carl Winter.
- Luís, Ana & Ricardo Bermúdez-Otero. 2016. *The morphome debate*. Oxford: Oxford University Press. 10.1093/acprof:oso/9780198702108.001.0001.
- Mamede, Bikila Ashenafi. 2018. *Documentation and description of Borna verb morphology: An Omotic language of Ethiopia*. Addis Ababa: Addis Ababa University dissertation. <http://localhost:80/xmlui/handle/123456789/16367>.
- Plazikowsky Brauner, Herma. 1950. Schizzo morfologico dello Šinaša. *Rassegna di studi etiopici* IX. 65–83. [www.jstor.org/stable/41460250](http://www.jstor.org/stable/41460250).
- Rapold, Christian. 2006. *Towards a grammar of Benchnon*. Leiden: Leiden University dissertation.
- Rapold, Christian. 2007. From demonstratives to verb agreement in Benchnon. In Azeb Amha, Maarten Mous, & Graziano Savà (eds), *Omotic and Cushitic studies: papers from the 4th Cushitic Omotic conference, Leiden, 10-12 April 2003*, 69–88. Cologne: Rüdiger Köppe Verlag.
- Reh, Mechthild. 1985. *Die Krongo-Sprache (Ninò Mó-Dì): Beschreibung, Texte, Wörterverzeichnis*. Berlin: Dietrich Reimer Verlag.
- Siewierska, Anna. 2013. Gender distinctions in independent personal pronouns. In Matthew S. Dryer & Martin Haspelmath (eds) *The world atlas of language structures online*. Leipzig: Max Planck Institute for Evolutionary Anthropology. [wals.info/chapter/44](http://wals.info/chapter/44), Accessed on 2019-11-09.
- Theil, Rolf (forthcoming). Kafa. In Ronny Meyer, Bedilu Wakjira, & Zelealem Leyew (eds), *The Oxford handbook of Ethiopian languages*. Oxford: Oxford University Press.
- Treis, Yvonne. 2014. Interrogativity in Baskeet. In Ronny Meyer, Yvonne Treis & Azeb Amha (eds), *Explorations in Ethiopian linguistics: Complex predicates, finiteness and interrogativity*, 41–78. Wiesbaden: Otto Harrassowitz.
- Wakasa, Motomichi. 2008. *A descriptive study of the modern Wolaytta language*. Tokyo: University of Tokyo dissertation.
- Wheeler, Alva. 1987. *Ganteya Bain: El pueblo Siona del río Putumayo*. Bogotá: Instituto Verano de Lingüística. [www.sil.org/resources/publications/entry/18858](http://www.sil.org/resources/publications/entry/18858).
- Yigezu, Moges & Teshome Yeshualashet. 1995. Anfillo: A sketch of grammar and lexicon. *Afrikanistische Arbeitspapiere* 44. 97–123.
- Zaugg-Coretti, Silvia. 2013. *The verbal system of Yemsa (Omotic language of Ethiopia)*. Zürich: University of Zürich dissertation. doi.org/10.5167/uzh-87425