

# **All-Digital Interface ASIC for a QCM-Based Electronic Nose**

J. M. Beeley, C. Mills, P.A. Hammond, A. Glidle, J.M. Cooper, L. Wang, D.R.S. Cumming

Department of Electronics & Electrical Engineering, University of Glasgow, G12 8LT, UK.

Email: [d.cumming@elec.gla.ac.uk](mailto:d.cumming@elec.gla.ac.uk) <http://www.elec.gla.ac.uk>

phone: +44(0)141 330 5233

fax : +44(0)141 330 4907

***Abstract:** An all digital interface, application specific integrated circuit (ASIC) has been developed for the control and data sampling of a quartz crystal microbalance (QCM)-based electronic nose. The ASIC is capable of measuring QCM resonant frequency between 0 – 11 MHz with a resolution of 1 Hz and +/- 1 Hz precision. The ASIC has been used to obtain measurements from polymer coated QCM sensors, in conjunction with polymer/carbon-black coated micro-resistance ( $\mu R$ ) sensors, in the detection of primary alcohols. A full SoC electronic nose, currently under test, which supports arrays of 8 QCM and 8  $\mu R$  sensors along with on-chip processing capability, is also described.*

***Keywords:** Quartz crystal microbalance (QCM), Microresistor, Electronic nose, Application Specific Integrated Circuit (ASIC), Frequency measurement, System-on-a-chip (SoC).*

## 1 Introduction

Quartz crystal microbalance (QCM) sensors have been successfully utilised in a range of electronic nose systems [1]. A QCM sensor consists of a quartz crystal, coated with an analyte-sensitive polymer. The analyte is adsorbed on contact onto the polymer coating's surface, increasing the mass of the QCM sensor and hence resulting in a change in resonant frequency. A QCM sensor coated with a given polymer is multi-specific, i.e. it responds to multiple analytes, hence QCM-based electronic nose systems make use of an array of sensors, each using a distinct sensor coating.

A range of different interface circuit designs have been used with QCM sensors. Some use the QCM as the resonant element in a digital logic-gate based oscillator circuit, the resulting oscillation frequency being measured by either a digital frequency counter implemented in a Field-Programmable Gate-Array (FPGA) [2,3], or a frequency-to-voltage converter driving an analog-to-digital PC data acquisition card [4,5]. Use of a more sophisticated oscillator design, formed from operational amplifiers and a voltage-controlled oscillator (VCO), permits the loading effect when the sensor is immersed in a liquid analyte to be compensated for, and thus may be used in a QCM-based electronic tongue [6]. However in the case of an electronic nose measurement of resonant frequency alone is sufficient. The electronic nose system developed at the University of Glasgow uses QCM and microresistor ( $\mu R$ ) sensor pairs, which have been shown [4,5] to require a significantly reduced number of different coating materials in comparison to systems based on a single sensor type.

All of the existing QCM-based electronic nose interface systems are relatively bulky, due to the use of numerous discrete electronic components. Additionally those based on FPGA technology will also tend to draw relatively high levels of current from the power supply. In order to overcome these limitations a QCM sensor interface ASIC has been developed. This offers advantages of substantially reduced size and power consumption in comparison to existing interface implementations, and is of particular value in battery-powered portable applications and in remote systems which may be powered by alternative energy. The QCM interface ASIC also provides reusable intellectual property (IP) which is utilised in a system-on-a-chip nose.

## 2. Frequency Measurement Method

The interface ASIC was required to measure QCM resonant frequency to a resolution of 1 Hz, with 10 frequency measurements per second. The conventional digital frequency measurement method, which uses a counter whose input is gated for a fixed measurement period, would require 10 counters for a single sensor to achieve the required 1 Hz resolution. Clearly this approach would need a large amount of silicon area. Hence an alternative all-digital frequency measurement method was developed.

The QCM forms the resonant element in a CMOS oscillator, whose output increments a digital counter. The counter's value rolls over to zero after  $11 \times 10^6$  counts. The counter's value is sampled every 100ms, and the 11 most recent counter samples stored in a first in, first out (FIFO) memory. We label these  $S_n$  to  $S_{n-10}$ , with  $S_n$  being the most recently acquired. The input frequency  $f_n$ , measured over a period of 1 second to achieve the required 1 Hz resolution, is then obtained as follows:

$$\text{If } S_n \geq S_{n-10} \text{ then } f_n = S_n - S_{n-10}$$

$$\text{else } f_n = S_n - S_{n-10} + 11 \times 10^6$$

The basic operation is illustrated in Fig. 1. In Fig. 1a the counter value rises monotonically, hence the frequency is simply the increase in the counter's value over the 1-second measurement period, which is the difference of the two samples. In Fig. 1b the counter rolls over to zero in between the two samples of its value being taken, and thus  $11 \times 10^6$  must be subtracted from the difference to take account of this fact. Thus a new frequency measurement is made every 100ms. Figures 2 and 3 illustrate the frequency measurement method's practical implementation in hardware.

This method achieves the required 1Hz resolution, with a precision of 1Hz, this being determined by the interval between the samples being used for the add/subtract operation outlined above, in this case 1 second. An increase in this interval will yield a proportional increase in resolution and precision. The upper bound on the frequency which may be measured is equal to the maximum value of the counter, in this case  $11 \times 10^6$  counts/sec, as an input frequency in excess of this value would cause the counter to roll over twice in one measurement period, producing erroneous data. The rate at which the counter value is sampled (in this case 10 samples/second) determines the maximum rate at which updated frequency measurements may be generated.

### 3 ASIC construction

The QCM interface ASIC interface is fabricated using Austria Mikro Systems' (AMS) "CUQ" 0.6  $\mu\text{m}$  2-metal mixed-signal CMOS process, via the Europractice multi-product wafer service. The digital design was specified in Verilog, simulated via the Synopsys VCS simulator and synthesised using Synopsys Design Compiler software. Cadence Silicon Ensemble was used to place-and-route each of the two digital blocks and Cadence Virtuoso was used to facilitate final chip assembly.

The chip consists of three main functional units (figs. 2, 4). Firstly, a CMOS oscillator (a standard AMS library component located in the padding) to which the QCM sensor is connected. The second component is the counter block, whose value is incremented by the QCM oscillator. The counter block generates a 24-bit sample output, whose value is updated every 100ms. This output feeds into the output block, which stores the 11 most recent counter value samples in a FIFO (Fig. 3), from which it calculates the QCM resonant frequency using the method described above. The output block's 24-bit output is made available externally along with a "data ready" signal and is sent to an 8255 Input/Output card located in a personal computer (PC) to provide data acquisition and logging.

### 4. Experimental Work

The ASIC has been tested using a 10 MHz QCM sensor within an electronic nose system (fig. 5), in conjunction with a micro-resistance ( $\mu\text{R}$ ) sensor, comprising interdigitated finger electrodes. Both sensors are coated with poly(ethylene-co-vinylacetate) (PE-co-VA), with carbon black deposited in the polymer matrix in the case of the  $\mu\text{R}$  sensor [7].

The electronic nose system has been used to produce headspace analysis of alcohol vapours,  $\text{C}_n\text{H}_{2n+1}\text{OH}$ , where  $n = 1$  to 8 and 10. Plots of the ratio of the response from the PE-co-VA coated QCM and the  $\mu\text{R}$  sensors,  $S_{\text{fr}}$ , versus relative molecular mass (RMM) and alcohol liquid density (fig. 6) show a linear relationship for alcohols where  $n > 2$ , despite a very non-linear response for  $\Delta f$  and  $\Delta R$  produced by the respective sensors (inset).

As the QCM response is proportional to a change in mass, and the  $\mu\text{R}$  response is proportional to a change in volume,  $S_{\text{fr}}$  can be defined as [4,5],

$$S_{fr} = \frac{(\Delta f / f_c)}{(\Delta R / R_0)} \propto \frac{\Delta m}{\Delta V} \propto \rho_A \quad (1)$$

where  $\Delta f$  and  $\Delta R$  are the frequency and resistance changes of the respective sensors.  $f_c$  and  $R_0$  are, respectively, the QCM resonant frequency change upon polymer deposition and the baseline resistance value of the  $\mu R$  sensor,  $\Delta m$  and  $\Delta V$  are the mass and volume change of the polymer deposited on the QCM and  $\rho_A$  is the density of the adsorbed analyte. Also,

$$\frac{1}{S_{fr}} = \frac{Sk''\rho_p}{RMM_A} \quad (2)$$

where,  $S$  is a gas/polymer sensitivity coefficient,  $k''$  is a geometric constant related to the  $\mu R$  sensor electrodes,  $\rho_p$  is the polymer density and  $RMM_A$  is the relative molecular mass of the analyte. Therefore,  $S_{fr}$  should be proportional to the analyte density and RMM respectively.

Repeated measurement of methanol ( $n = 1$ ) vapour at concentrations of approximately 800 ppm and 1600 ppm (Fig. 7) reveals that  $S_{fr}$  is independent of concentration change, in contrast to  $\Delta f$  and  $\Delta R$  (inset). This concentration independence, allied to the linear properties of  $S_{fr}$  when detecting alcohols suggest that this system could be useful when designing electronic nose systems based on arrays of sensors for the detection of analyte gases with similar conformations.

## 5 System-on-a-Chip Electronic Nose

Following the successful development and experimental evaluation of the QCM sensor frequency measurement chip a second ASIC capable of supporting an array of QCM and potentiometric ( $\mu R$ ) sensor pairs was developed. This implements a full system-on-a-chip (SoC) electronic nose.

It provides interfaces for an array of 8 QCM sensors, and 8  $\mu R$  sensors along with an on-chip microprocessor, as depicted in Fig. 8. Each QCM sensor is connected to an on-chip oscillator and frequency counter, these being formed from IP which is re-used from the chip described above. The  $\mu R$  sensor array is connected to on-chip analog multiplexers which permits any one of the 8 sensors to be selected as the feedback element in an inverting op-amp circuit, whose output is fed to a 10-bit analog-to-digital converter. Data acquisition is controlled by an on-chip 6805 embedded processor. This is in-system programmable and has a 2K SRAM block of program memory. An 8-bit on-chip bus permits the processor to acquire measurements from the

sensor interfaces, as well as facilitating  $\mu$ R sensor selection and the initiation of, and reading results from, A-to-D conversion. An on-chip serial interface provides a connection point to a PC or other device for data logging. The sensors and external interface are implemented as addressable peripherals on the bus. Figs. 8 and 9 depict the SoC electronic nose chip.

We wish to thank Cathy Wyse for additional work on this project. This research is supported by the UK Engineering and Physical Sciences Research Council.

## References

- [1] K. J. Albert, N. S. Lewis, C. L. Schauer, G. A. Sotzig, S. E. Stitzel, T. P. Vaid, D. R. Walt, "Cross-Reactive Chemical Sensor Arrays", *Chem. Rev.* 100 (2000) 2595-2626.
- [2] R. Stone, P. A. Payne, Measurement Of The Response Of Resistive Sensors Using Logic Oscillators And Integrated Frequency Measurement, *Sensors-and-Actuators-A-(Physical)*. vol.A76, no.1-3, pp431-6, 30 Aug. 1999.
- [3] C. Di Nucci, A. Fort, S. Rochhi, L. Tondi, N. Ulvieri, V. Vignoli, F. Di Francesco, M Serrano-Santos, "Study of the Dynamic Response of QCM Sensors by Means of a Fast and Accurate All-Digital Frequency Sensor", In: *IEEE Instrumentation and Measurement Technology Conference*, pp. 33-38, Anchorage, USA, 21-23 May 2002.
- [4] L. Cui, M. J. Swann, A. Glidle, J. R. Barker, J. M. Cooper, "Odour Mapping Using Micro-resistor and Piezo-Electric Sensor Pairs", *Sens. and Actuators B: Chem.* 66 (2000) 94-97.
- [5] M. J. Swann, A. Glidle, L. Cui, J. R. Barker, J. M. Cooper, "The Determination of Gaseous Molecular Density Using a Hybrid Vapour Sensor", *Chem. Commun.* (1998) 2753-2754.
- [6] . V. Ferrari, D. Marioli, A. Taroni, Oscillator Circuit Configuration for Quartz-Crystal-Resonator sensors Subject to Heavy Acoustic Load *Electronics Letters*, 30th March, Vol 36, No.7, IEE 2000.
- [7] M. C. Lonergan, E. J. Severing, B. J. Doleman, S. A. Beaver, R. H. Grubbs, N. S. Lewis, "Array-Based Vapor Sensing Using Chemically Sensitive, Carbon Black-Polymer Resistors", *Chem. Mater.* 8 (1996) 2298-2312.
- [8] Miller J. C., Millar J.N., "Statistics for Analytical Chemistry: 3<sup>rd</sup> edition", Ellis Horwood, London, (1994) pp. 63.



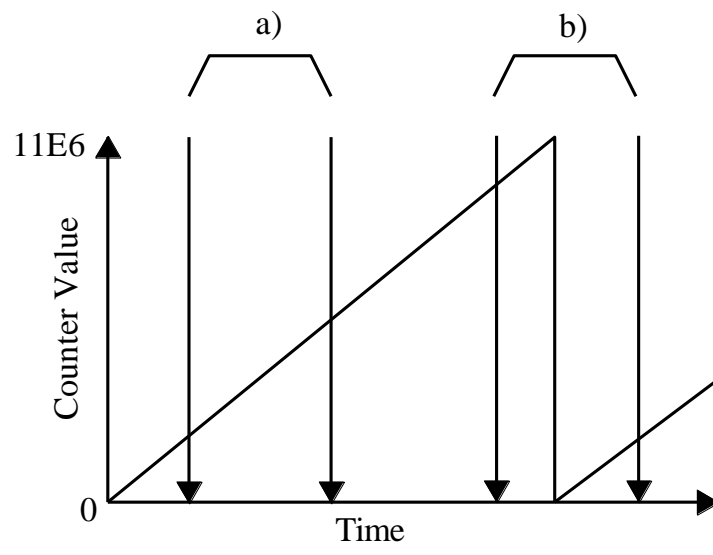

Fig. 1

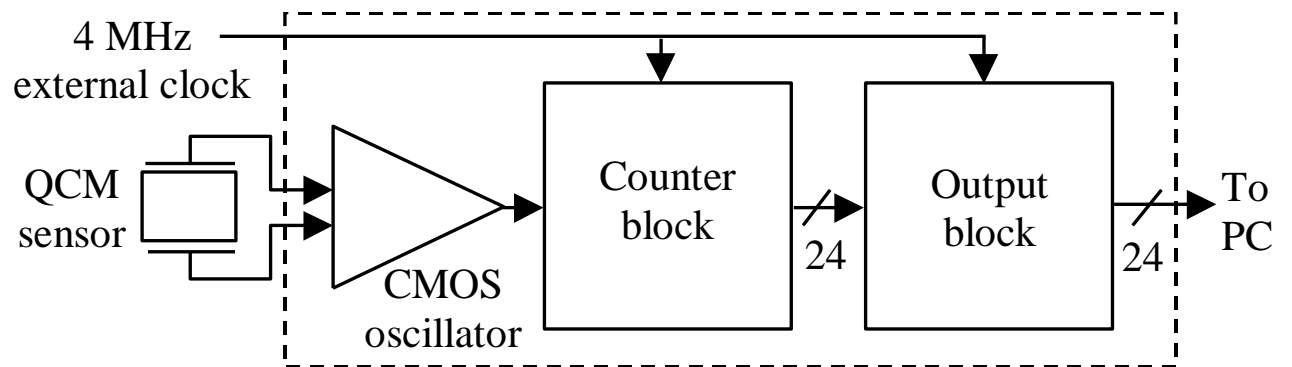

Fig. 2.

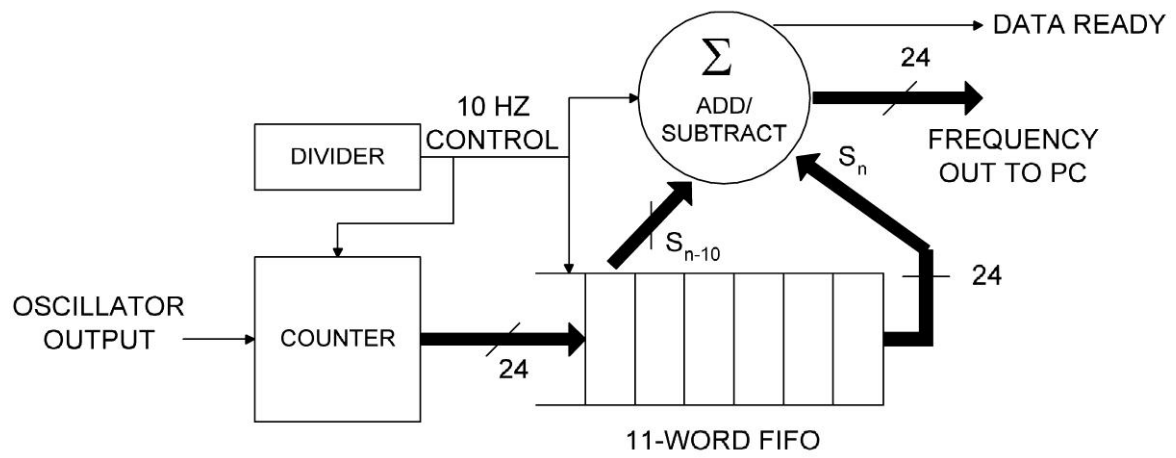

Fig. 3

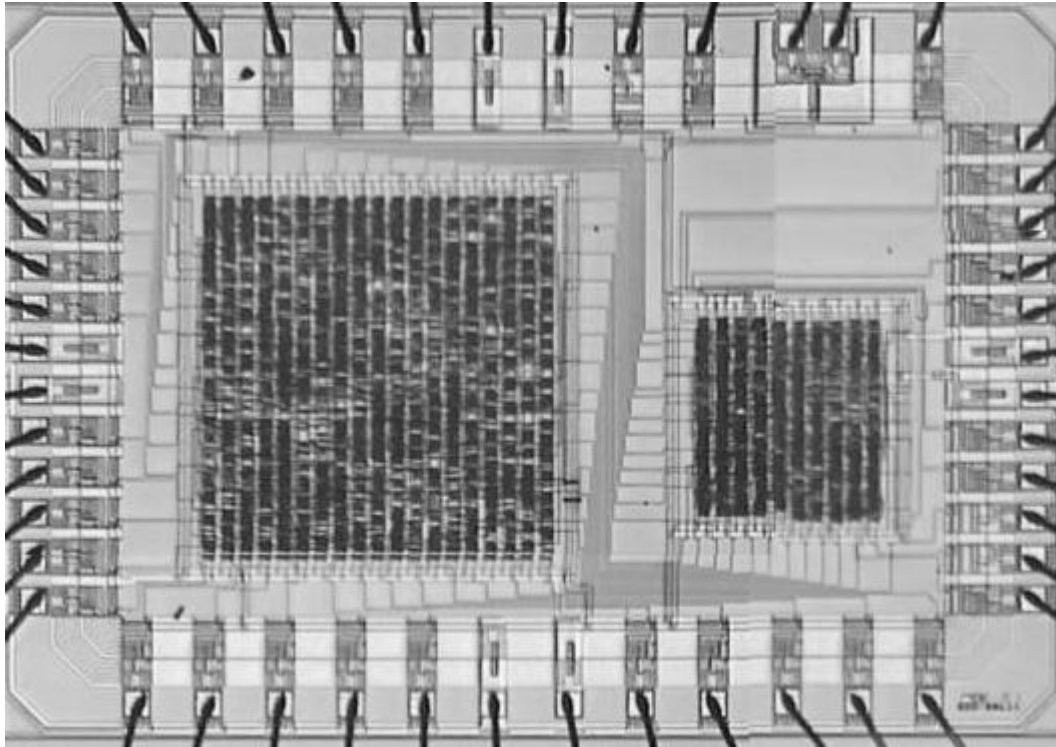

Fig. 4

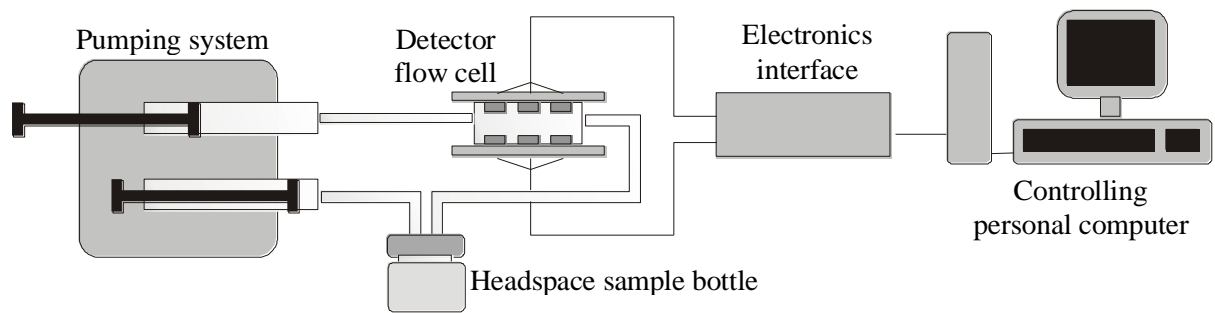

Fig.5.

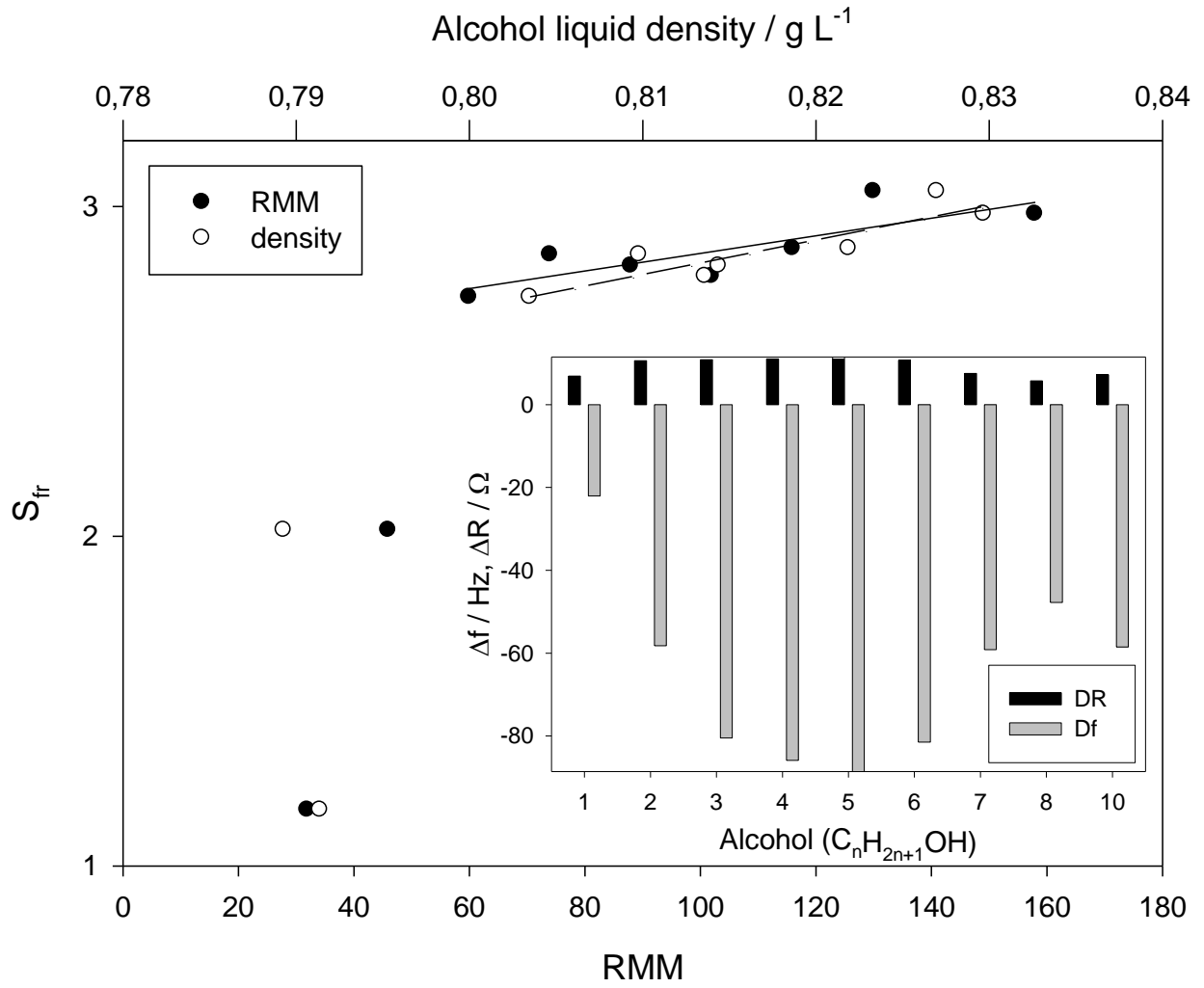

Fig. 6.

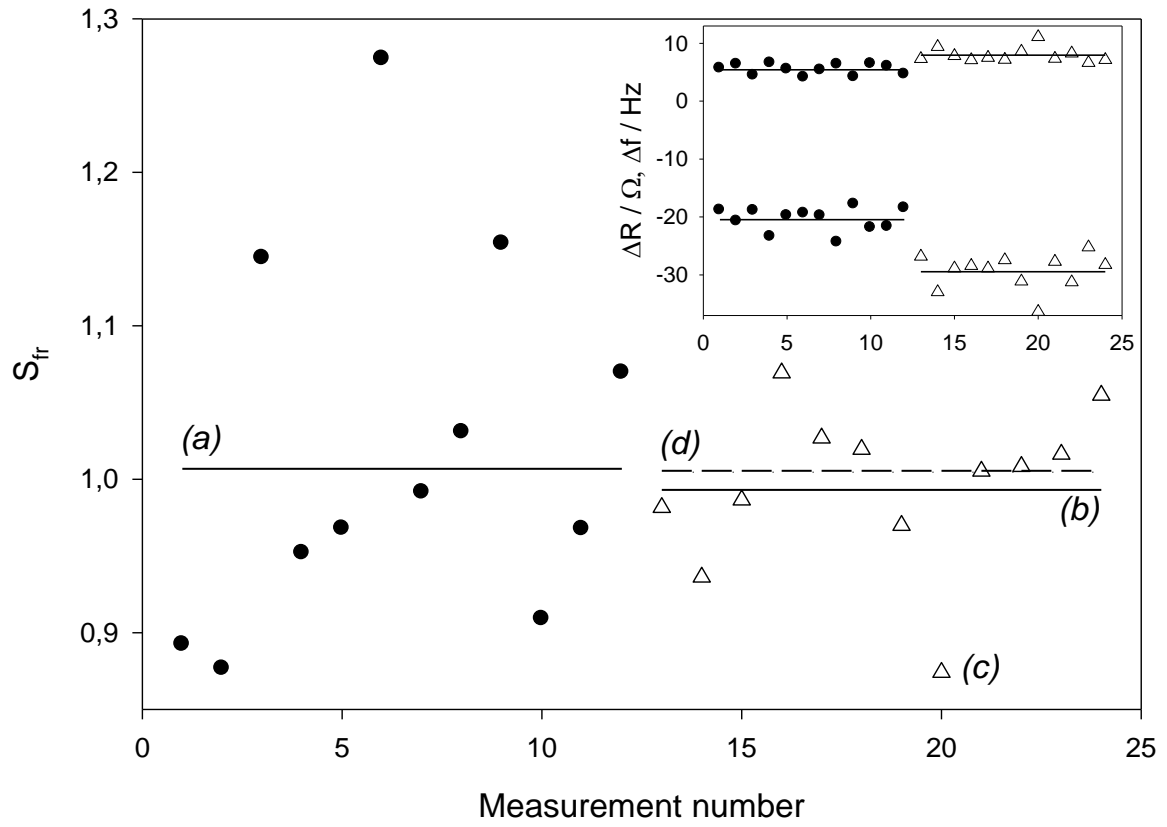

Fig. 7.

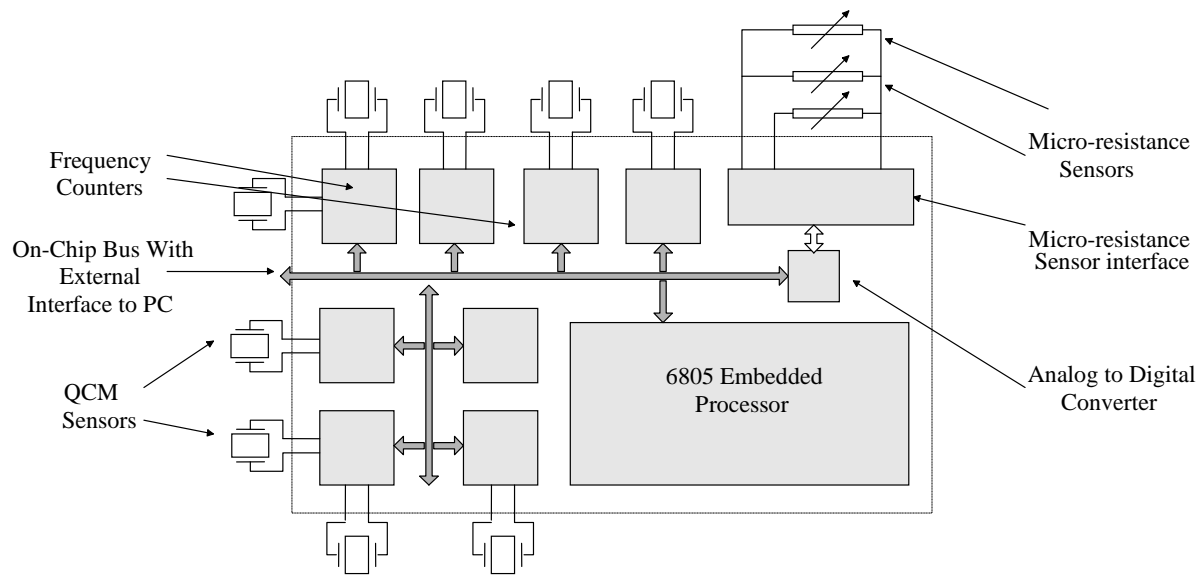

Fig. 8.



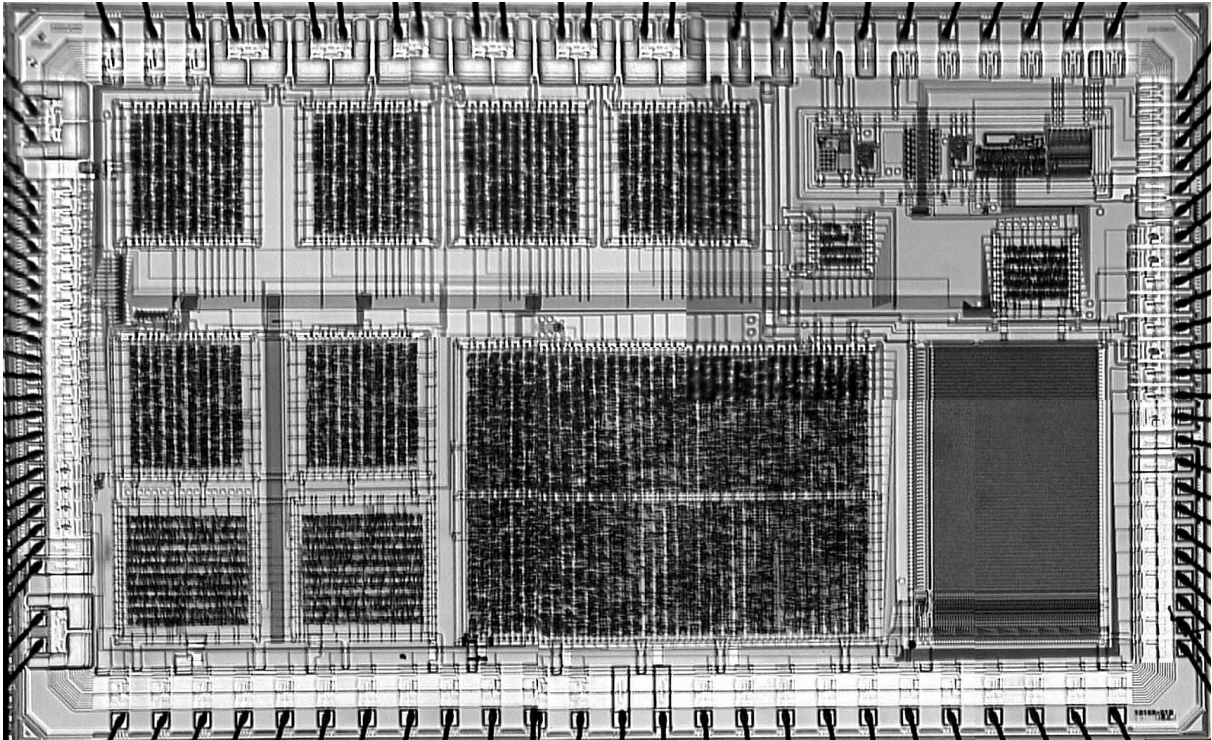

Fig. 9

Fig. 1 A graphical representation of the frequency measurement method that enables 10 samples a second with 1 Hz resolution.

Fig. 2. QCM interface ASIC block diagram.

Fig. 3. A schematic circuit of the data acquisition system.

Fig. 4 Electronic Nose QCM Interface ASIC. The ASIC is fabricated in a 0.6 $\mu$ m, 2-metal process, and is 3.8 x 2.5mm in size. The smaller block to the right is the counter, whilst the larger block to the left implements the buffering and adder/subtractor functionality for determining QCM resonant frequency from the counter's output. The oscillator used with the QCM sensor is located within the pad ring at top right.

Fig. 4. A photo-micrograph of the frequency counter ASIC.

Fig.5. Electronic nose experimental apparatus consisting of an infusion/withdrawal pumping system, a detector flow cell, detector electronics interface and a controlling personal computer. Analyte gasses are introduced from a headspace sample bottle, and passed repeatedly through the sensor flow cell by the pumping system.

Fig. 6  $S_{fr}$  versus RMM and alcohol liquid density calculated using  $\Delta R$  and  $\Delta f$  (inset) upon the introduction of primary alcohols ( $C_nH_{2n+1}OH$   $n = 1$  to 8 and 10) to PE-co-VA coated QCM and  $\mu R$  sensors. A linear relationship is seen for both the RMM (solid line) and liquid density (dashed line) for alcohols where  $n > 2$ .

Fig. 7  $S_{fr}$  for 12 repeat introductions of approximately 800 ppm (●) and 1600 ppm (Δ) of methanol to a pair of PE-co-VA sensors. The means (solid lines a and b) are plotted for each concentration. Upon removal of the outlier (c) using Dixon's Q-test [8], the mean of the 800 ppm measurements increases (dashed line d) to a value close to that of the 1600 ppm measurements. Inset,  $\Delta R$  and  $\Delta f$  for the 12 repeated introductions.

Fig. 8. Block diagram of the system-on-a-chip instrument for 8 QCM and 8  $\mu R$  sensors.

Fig. 9. A photo-micrograph of the 16 channel SoC nose chip.

## Author Biography

James Beeley received a B. Eng (Hons) degree from the University of Glasgow in 1997. He has recently submitted his doctoral thesis, "Design and Construction of a Distributed Crossbar Switch Hypermesh Parallel Computer". His current research interest is in designing custom ASIC interface electronics for electronic nose systems.

Jonathan M. Cooper, F.Inst.P, FIEE, FRSE is a Professor of Bioelectronics in the Department of Electronic and Electrical Engineering at the University of Glasgow. He was a member of the DTI-Foresight Lab-on-a-Chip (LOAC) Consortium and is now a principal applicant in the UK's Interdisciplinary Research Collaboration (IRC) in Bionanotechnology. He is on the Editorial Board of Biosensors and Bioelectronics, and the IEEE Trans. in Biological Nanoscience, as well as being Editor in Chief IEE Proc. in Bionanotechnology. He has around 100 publications in peer-reviewed journals. His current research interests lie in medical diagnostics, bionanotechnology and single cell analysis.

David Cumming has B.Eng (Glasgow, 1989) and PhD (Cambridge, 1993) degrees and is a MIEEE. He has worked variously on mesoscopic device physics, RF characterization of novel devices, fabrication of diffractive optics for optical and sub-millimeter wave applications, diagnostic systems and microelectronic design. He is presently a Senior Lecturer and EPSRC Advanced Research Fellow in Electronics and Electrical Engineering at the University of Glasgow, U.K. where he leads the Microsystem Technology Group.

Andrew Glidle has B.Sc. (Exeter 1984) and PhD (Exeter 1988) degrees and is a CChem and MRSC. He has developed a number of analytical methods in the fields of electrochemistry, physical chemistry, materials science and bioelectronics together with various methods for the specific immobilisation of chemical or biological motifs on sensor surfaces. He is a PDRA in the Bioelectronics Group at the University of Glasgow, UK.

Paul A. Hammond received the MEng degree from the University of Cambridge in 1999. Since then he has worked in industry as a CMOS analogue circuit designer. He is currently pursuing the PhD degree at the University of Glasgow. He is particularly interested in the use of system-on-chip techniques in sensing applications.

Chris Mills received a BSc. in Chemical Science from the University of Salford and, in 2000, a PhD from the University of Wales, Bangor, for studies on the electronic properties of semiconducting polymers. He then studied polymer-based electronic nose technology, as a Postdoctoral Researcher at the University of Glasgow, until 2003 and is currently a Ramon i Cajal Postdoctoral Researcher at the Barcelona Science Park working in the field of polymer-based nanotechnology.

Lei Wang received the B.Sc. degree in Information and Control Engineering and the Ph.D degree in Biomedical Engineering from Xi'an Jiaotong University, Xi'an, China, in 1995 and 2000, respectively. He is an MIEEE. After graduation, he was an Academic Visitor with the Department of Mechanical Engineering, University of Dundee, U.K. In 2001, he joined the Department of Electronics and Electrical Engineering, University of Glasgow, U.K., as a Post Doctoral Researcher. His research interests focus on physiological measurement, digital signal processing, and integrated circuit design.